



Service public fédéral
Personnel et Organisation

E-Procurement

Federale Dienst e-Procurement

Waldo Van den Broeck

.be



Inhoud

- Huidige situatie
- Korte demonstratie
 - e-Notification
 - e-Tendering
- Principes uitrol Vlaamse Overheid
- Bespreking samenwerkingsakkoord
- Mogelijke ondersteuning vanwege de dienst e-Procurement

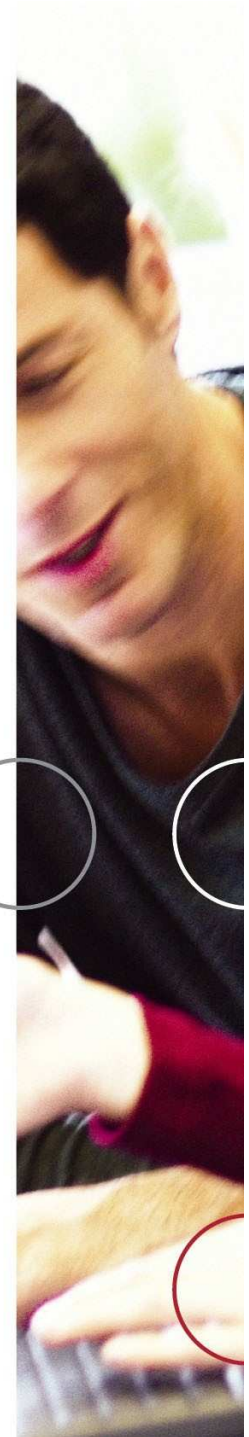
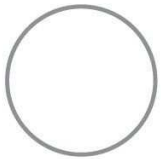
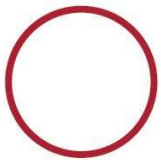



Service public fédéral
Personnel et Organisation

Huidige situatie

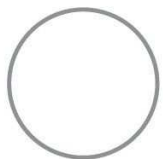
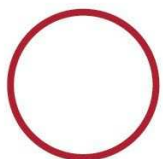

.be

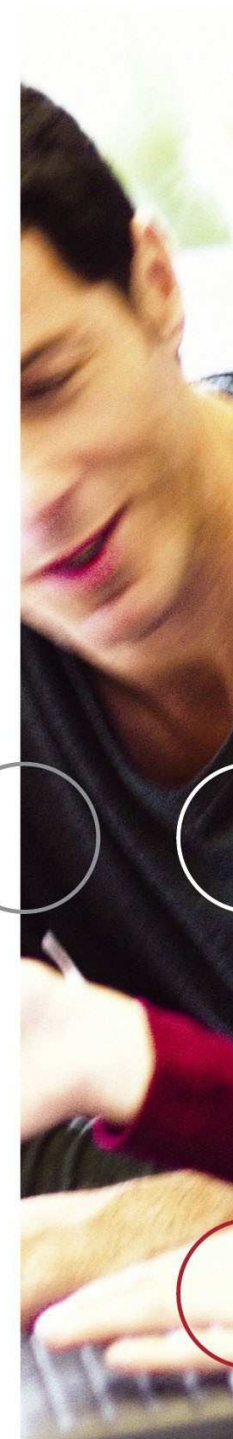



Wat is e-procurement?

- Het elektronisch laten verlopen van het aankoopproces
 - Via internet
 - Front-end
- Proces
- Publicatie => gunning en beheer contract

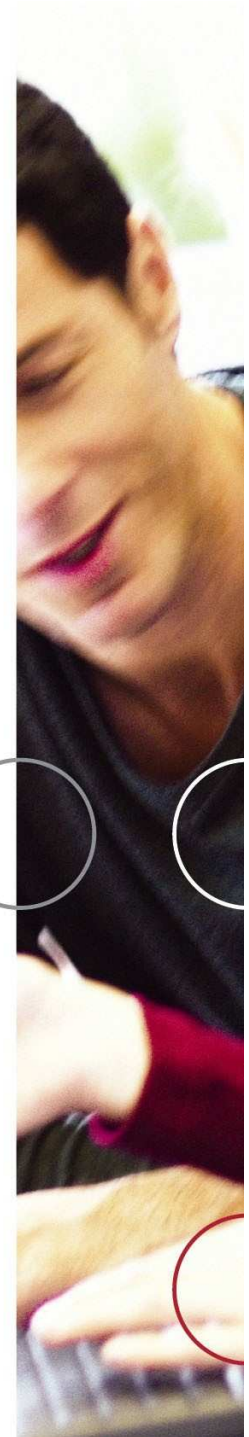
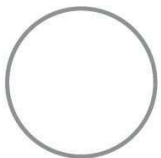



Fasen in een overheidsopdracht

- de bekendmaking;
- de indiening en de opening van kandidaturen en offertes;
- de evaluatie en de kennisgeving;
- de elektronische veiling (nog niet in uitvoering);
- het gebruik van catalogi;
- de facturatie en de betaling

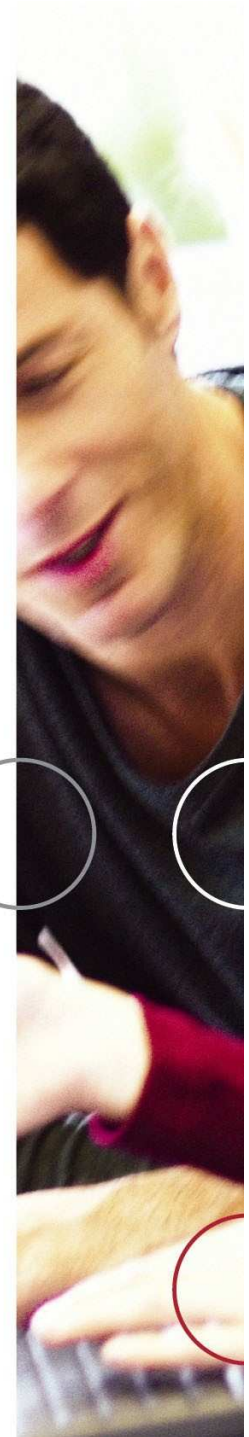
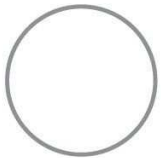
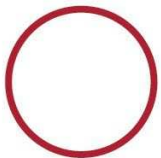



Overeenkomstige modules

De bekendmaking	➔	E-notification
Indienen en openen offertes/kandidaturen	➔	E-tendering
Evaluatie en kennisgeving	➔	E-awarding & e-notification
Omgekeerde veiling	➔	E-auction
Beheren catalogus	➔	E-catalogue
Facturatie & betaling	➔	E-invoicing & e-payment (Fedcom)





Europese doelstelling

- Europese Ministerraad van Manchester in 2006:
- Tegen eind 2010
 - Overheidsadministraties moeten in staat zijn om hun **overheidsopdrachten volledig elektronisch** te laten verlopen
 - Minstens **50%** van de opdrachten boven de Europese publicatiedrempels moeten **daadwerkelijk elektronisch** gebeuren

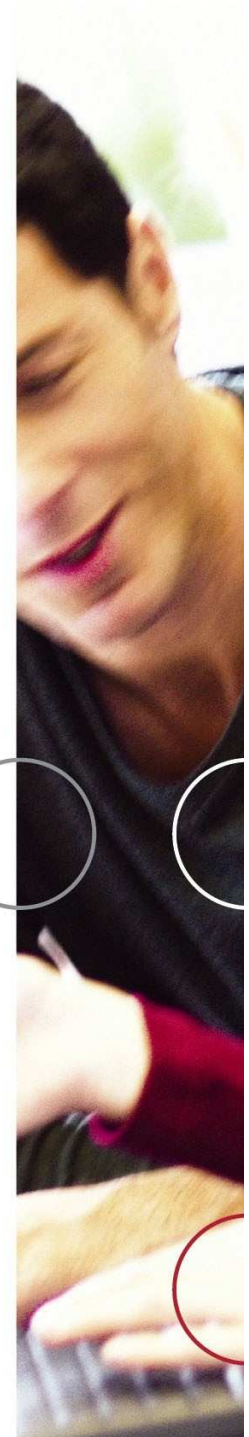
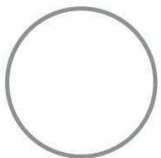
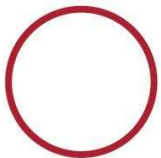



Het belang van e-procurement

- Overheidsopdrachten vormen in Europa 15 à 20% van het BNP
- Het gebruik van e-Procurement tools moet significante besparingen opleveren

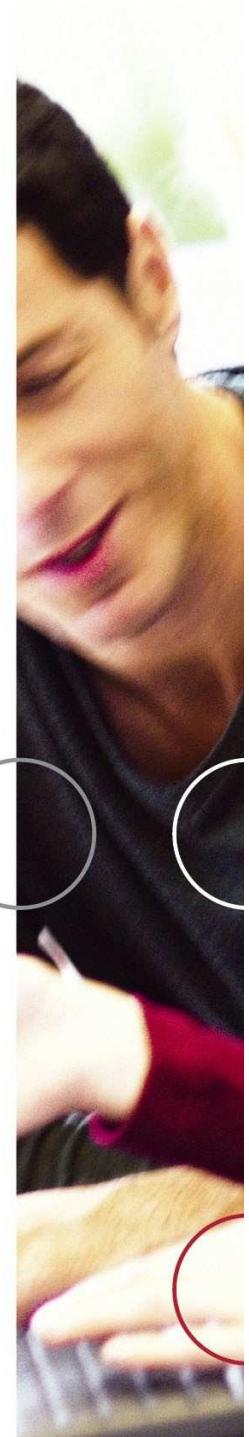
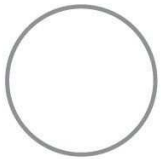
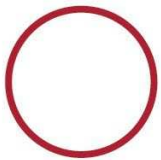



Doelstellingen

- Verbetering van de doeltreffendheid en de efficiëntie van het aankoopproces
- Administratieve vereenvoudiging
- Concurrentieverbetering
- Verbetering transparantie overheidsopdrachten
- Algemeen
 - Voor administraties: beter kopen
 - Voor ondernemingen: beter verkopen

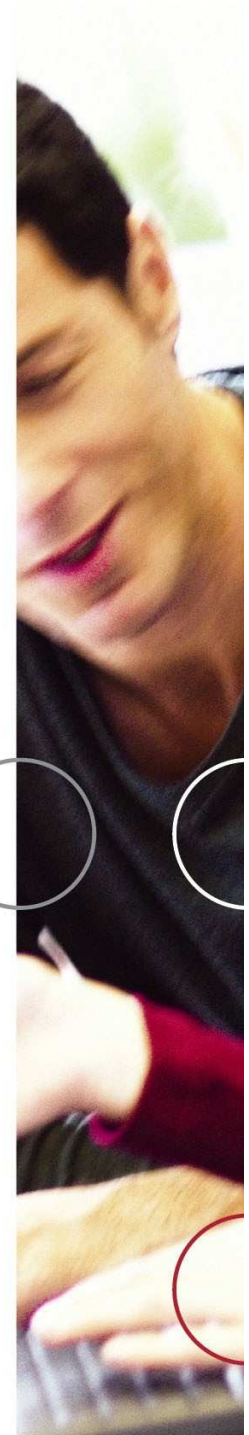
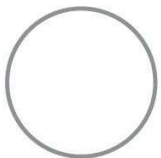
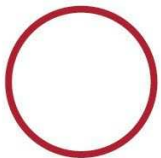



Het landschap

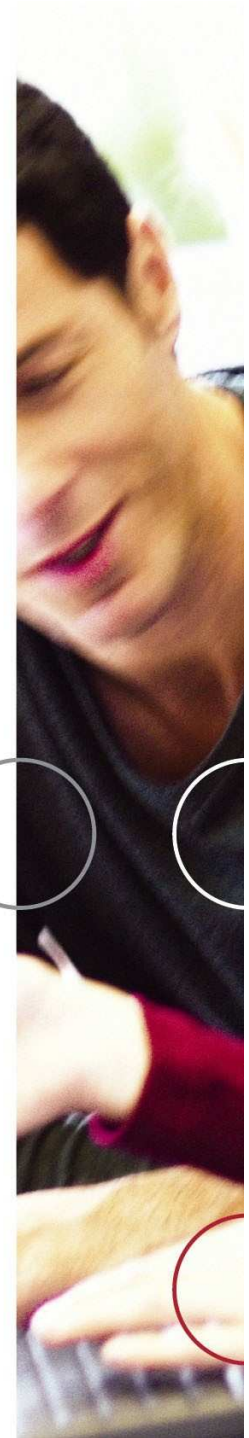
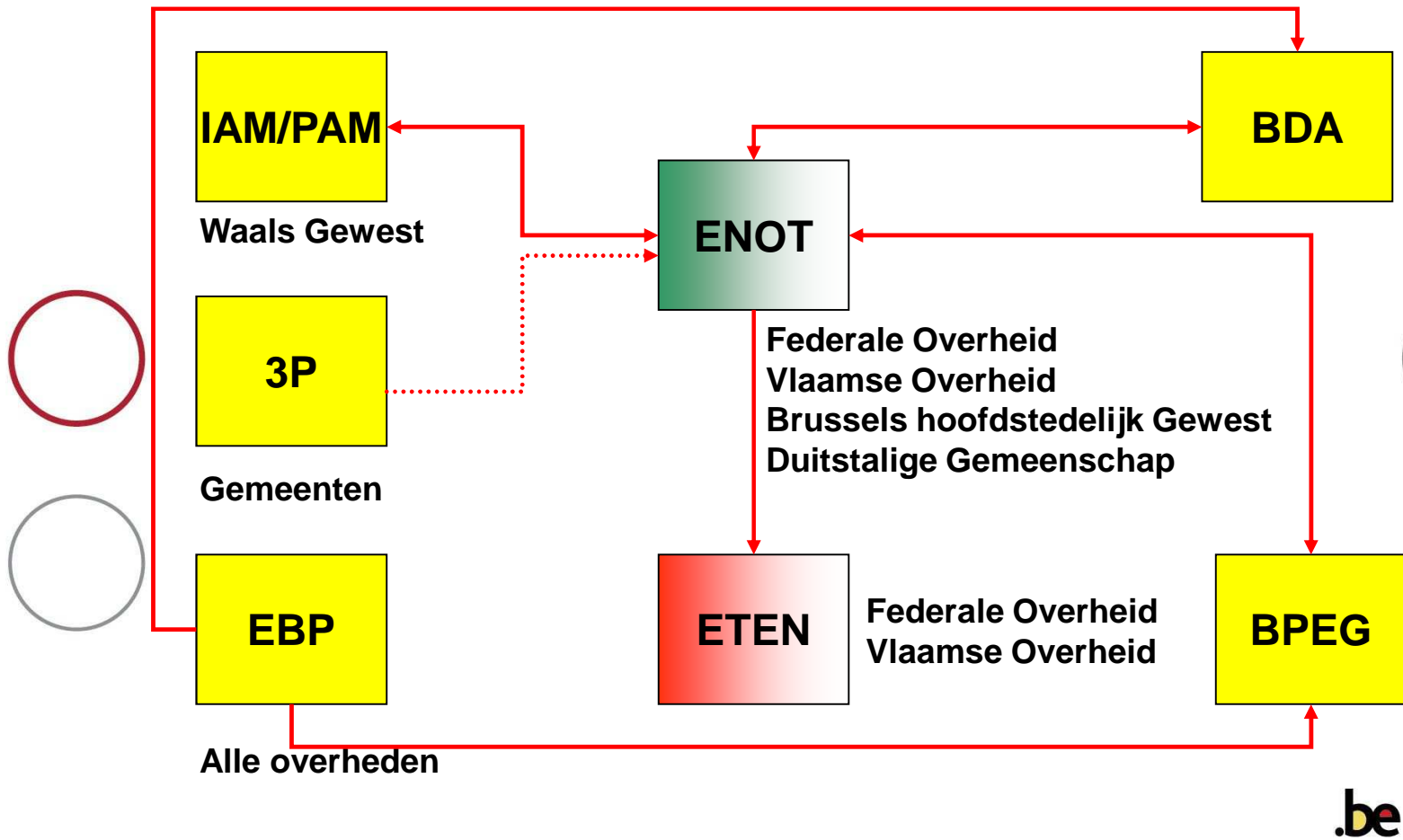



Het landschap - toekomst

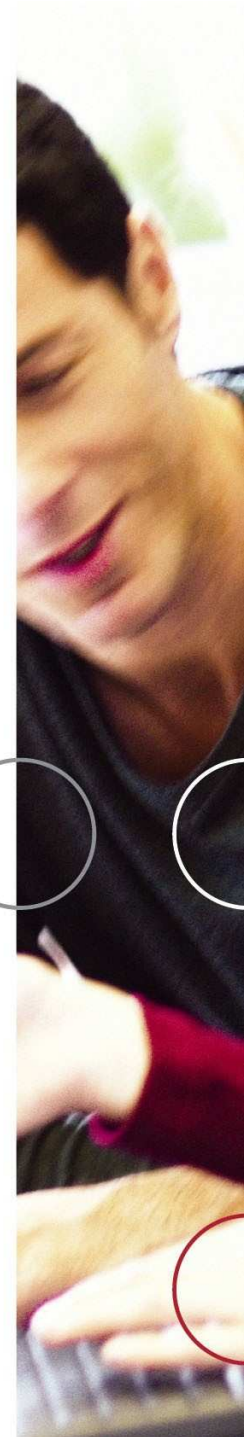
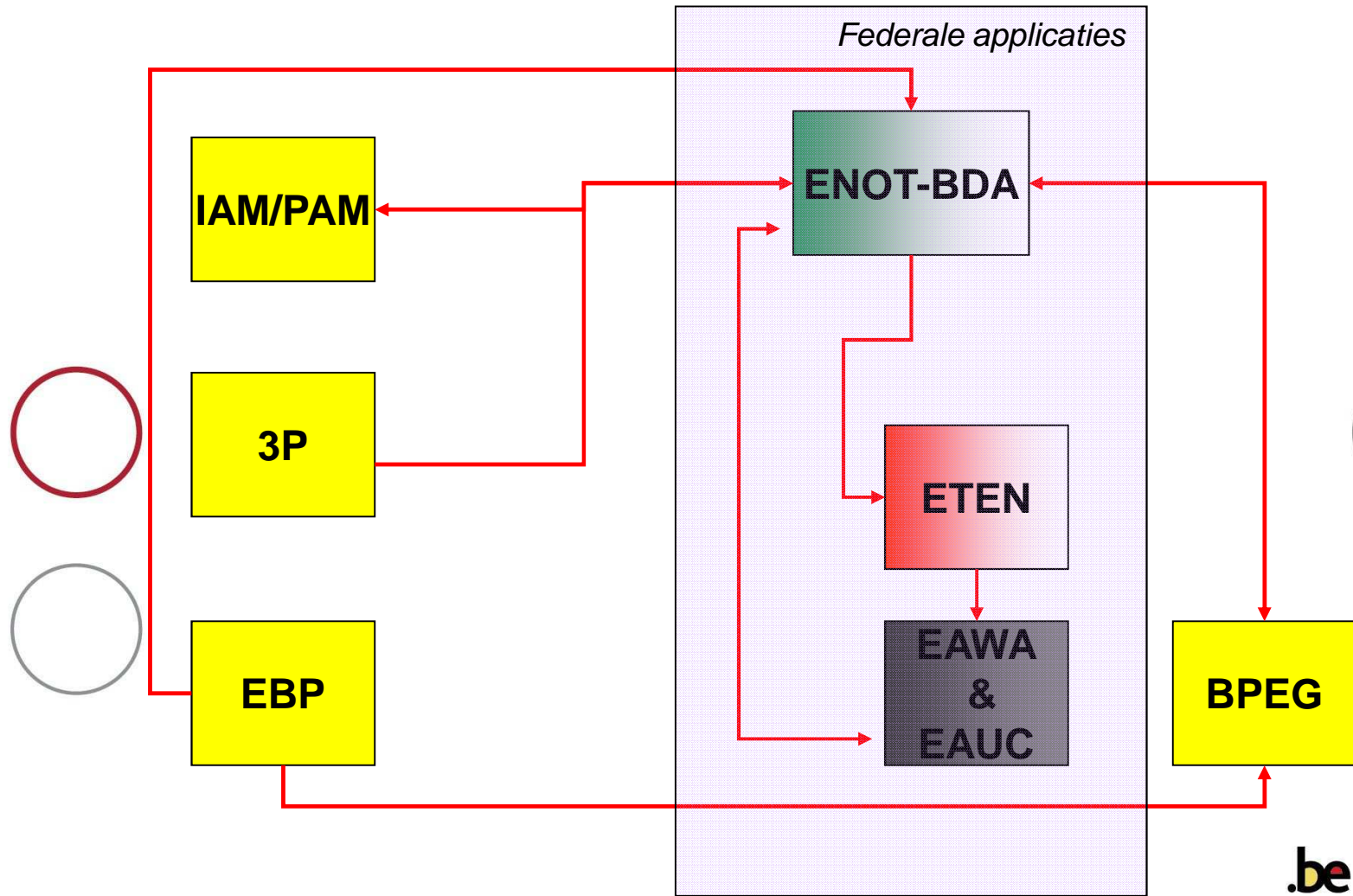



Gebruik

- Het aantal elektronische publicaties rechtstreeks via eNotification (voordien JEPP)

2004	213
2005	433
2006	997
2007	1590
2008	2310
2009	3996

- Gemiddeld werden 68,5% van de federale aankondigingen via e-Notification gepubliceerd

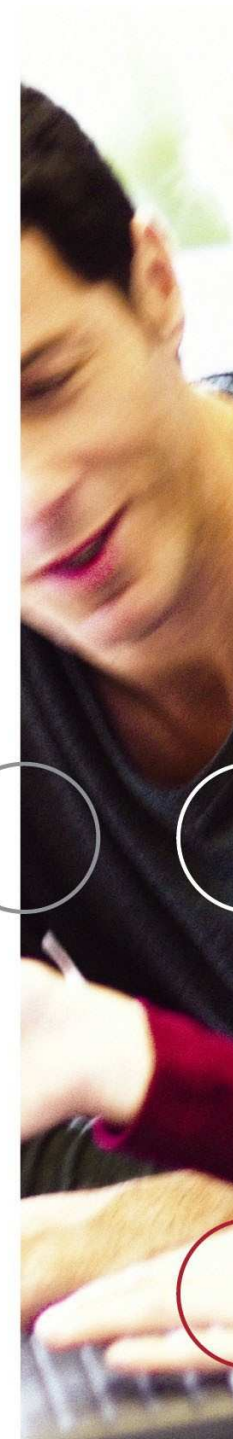



Service public fédéral
Personnel et Organisation

Helpdesk

- Tweetalig
- 8:30 – 16:30
- NL
 - 02 790 52 58
 - e.proc@publicprocurement.be
- FR
 - 02 790 52 66
 - e.proc@publicprocurement.be
- **Gratis**

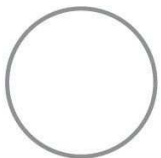

.be

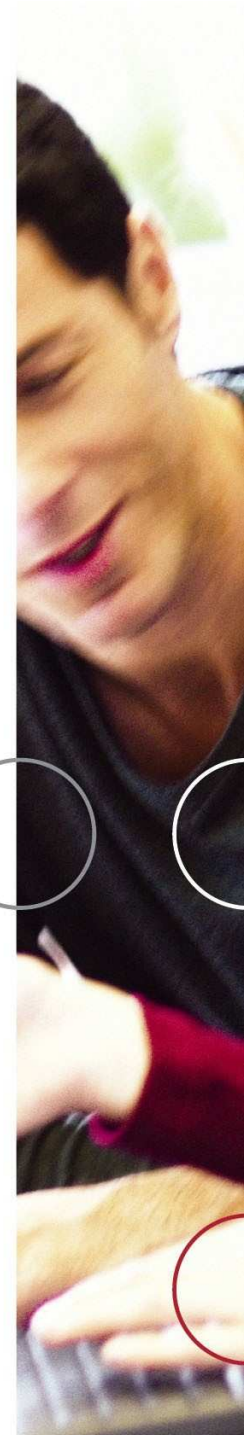



Service public fédéral
Personnel et Organisation

Demonstratie e-Notification

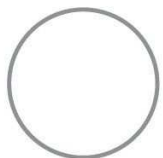
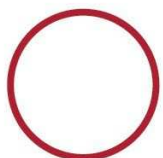

.be

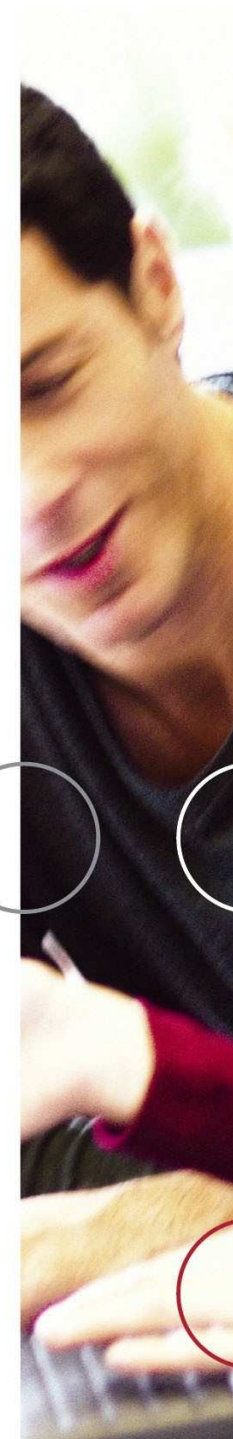



Soorten gebruikers

- Anonieme gebruiker
- Onderneming
- Openbare aankoper
 - **Superuser**
 - Verantwoordelijk voor een (sub)organisatie en zijn gebruikers
 - **Uitgever**
 - Verantwoordelijk voor een publicatie
 - **Editor**
 - Verantwoordelijk voor de voorbereiding van een publicatie
- Administrator
 - De helpdesk staat in voor het beheer van de applicatie

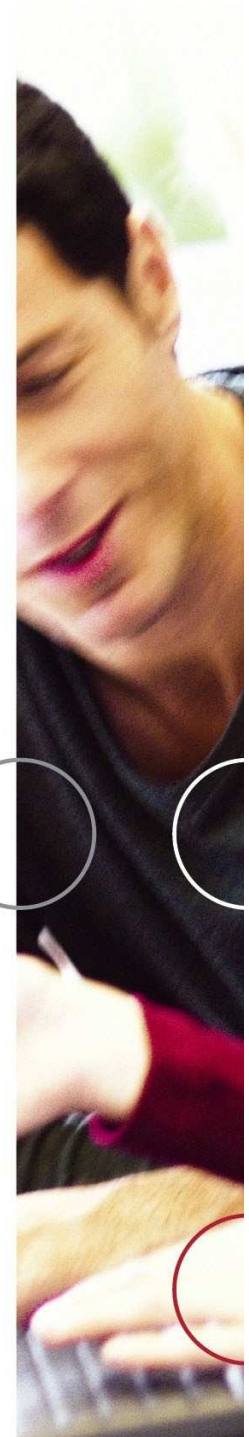
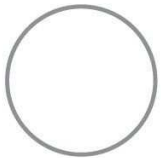
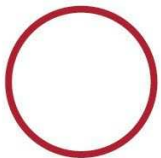



Service public fédéral
Personnel et Organisation

e-Notification

- Functionaliteiten

- Publicatie van alle Europese aankondigingen (14 formulieren)
- Online plaatsen van bestek en begeleidende documenten
- Geavanceerde zoekmotoren
- zoekprofielen
- Automatische mailings
- Q&A
- e-Marketplace (sourcing)
 - Business cards voor leveranciers
 - Eenvoudige aankondigingen(onder drempel)
- Super users
- Workflow

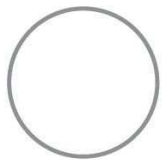



Startpagina e-Notification (JEPP2)

- Via de portaalsite: www.publicprocurement.be
- Rechtstreeks: <https://enot.publicprocurement.be>

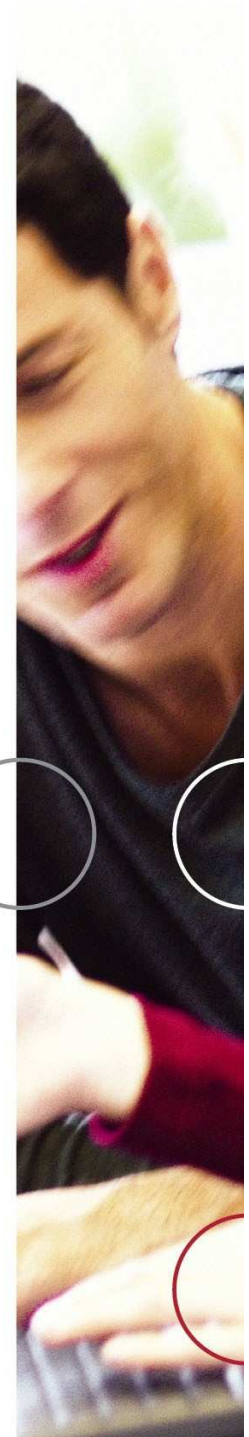
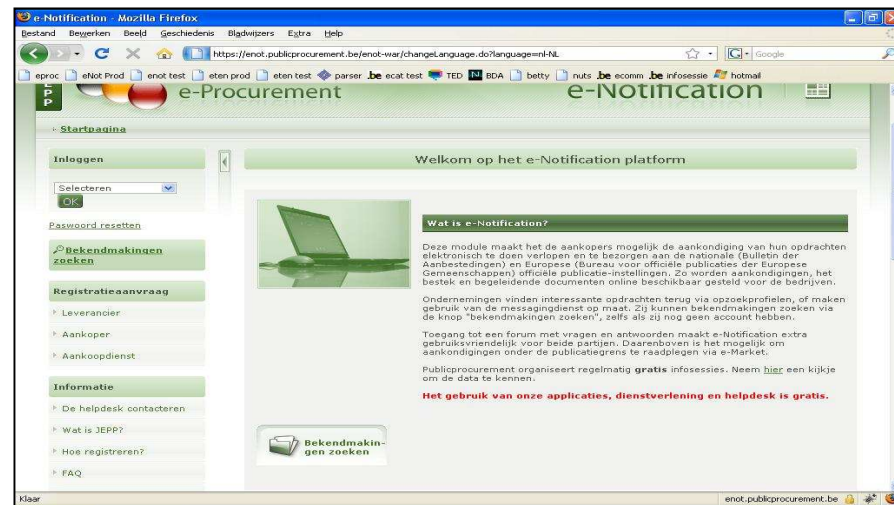



Bekendmakingen zoeken

20 criteria

Inloggen

Overheid

Selecteren

OK

[Password resetten](#)

Bekendmakingen Zoeken

Bekendmakingen zoeken

Zoekcriteria

Geavanceerde opties tonen / niet tonen

Bekendmaking zoeken in

e-Market JEPP

Zoeken Aankondigingen statuut

Actieve Inactieve Alles

De CPV begint met

CPV-codes

NUTS-codes

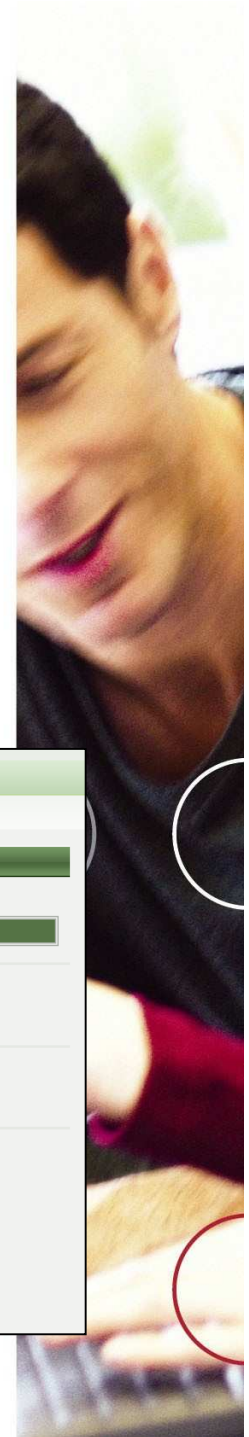
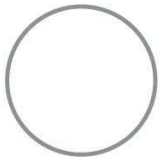



Zoekresultaten

- Een **dossier**:
 - Vooraankondiging
 - Aankondiging van opdracht
 - Aankondiging van gunning
 - Errata
 - Bestek
 - Begeleidende documenten
- } Ook nutssector, ...

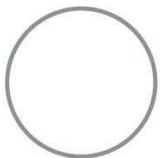
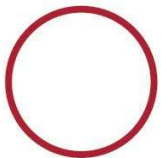

➔ Bij elkaar horende aankondigingen worden gebundeld op dezelfde pagina (in één dossier)

➔ Bij erratum is een volledige versie van de aangepaste aankondiging zichtbaar (uitgezonderd erratum document)

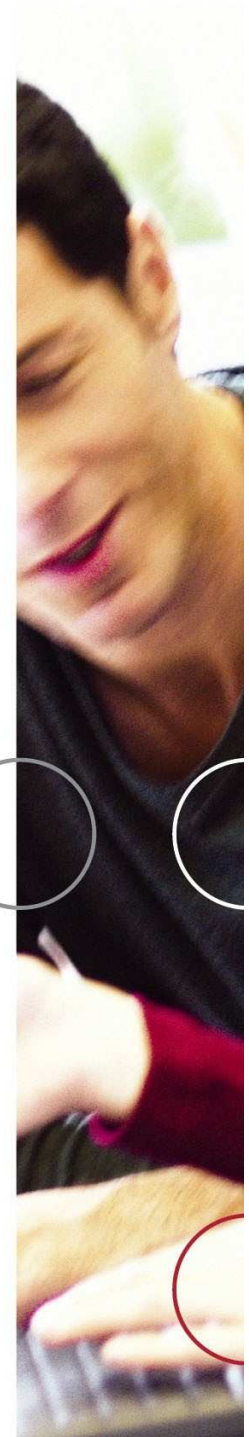



Service public fédéral
Personnel et Organisation

Demonstratie e-Tendering

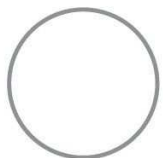
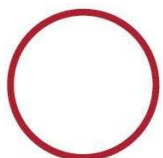

.be

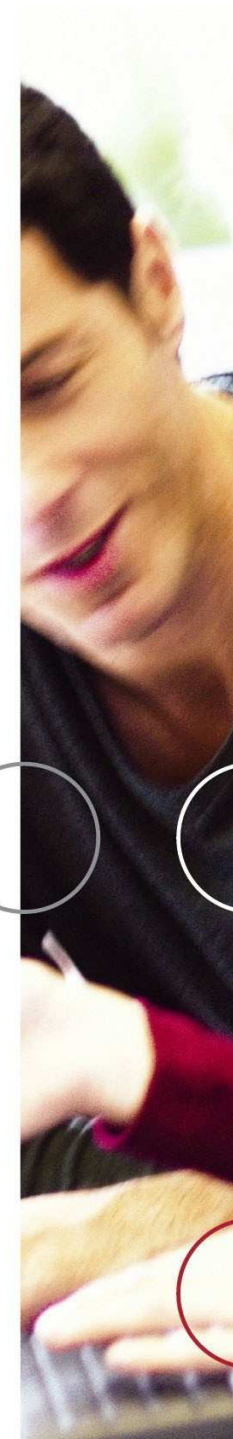



Service public fédéral
Personnel et Organisation

e-Tendering

- Algemeen
 - Indienen en openen van elektronische offertes
 - Integratie met e-Notification
 - Ondersteuning van papieren offertes

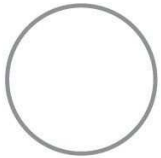



Soorten gebruikers

- Onderneming
 - Zich registreren
 - Dossier zoeken en raadplegen
 - Offertes indienen
 - Offertes intrekken vóór de opening
 - PV van opening consulteren
- Openbare aankoper
 - Zich registreren
 - Eigen dossier zoeken en raadplegen
 - Configureren van dossier
 - Openen offertes/kandidaturen
 - Aanmaken PV van opening
 - Downloaden dossier data
- Administrator

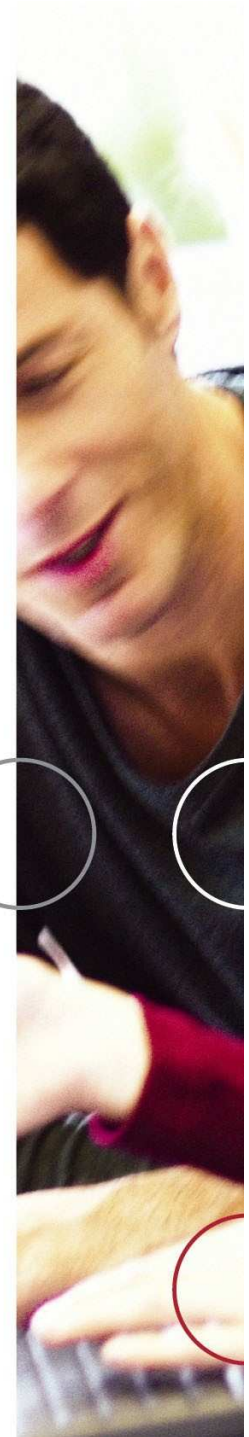
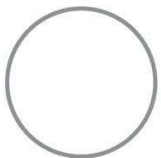



Service public fédéral
Personnel et Organisation

e-Tendering

- **Functionaliteiten**
 - Creatie dossier via e-Not.
 - Indienen van elektronische offertes
 - Ondersteunt e-ID en Certipost
 - Geen beperking van filetype en het aantal files
 - Openen van de offertes
 - 4-eyes principle
 - Validatie certificaat
 - Automatische creatie van PV van opening
 - info betreffende papieren offertes
 - commentaren
 - ...

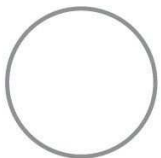



Service public fédéral
Personnel et Organisation

Elektronische offerte indienen

- Offerte = 1 of meerdere bestanden
- Elk type bestand is toegelaten
- Max grootte per bestand: 80 MB
- Digitaal ondertekend door indiener
- Tijdens het indienen wordt er een gecertificeerde tijdstempel aan offerte toegevoegd
- Encryptie van offerte; wordt pas tijdens de opening ongedaan gemaakt

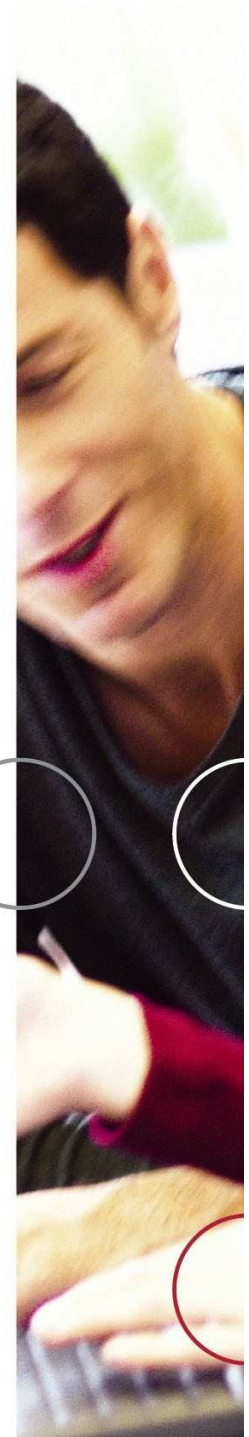
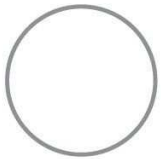



Startpagina e-Tendering

- Via de portaalsite: www.publicprocurement.be
- Rechtstreeks: <https://eten.publicprocurement.be>

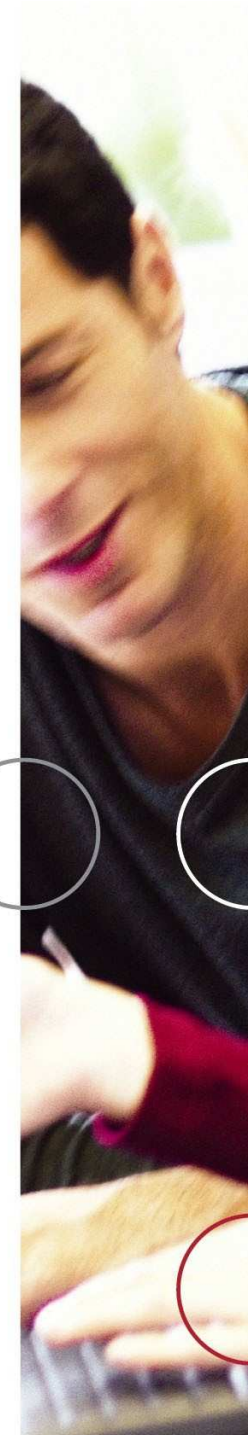



Principes uitrol binnen de Vlaamse Overheid

- Beslissing Ministerraad om (verplicht) gebruik te maken van e-Notification en e-Tendering
- E-Notification
 - Training
 - helpdesk
 - Uitrol in 2009
 - Monitoring van de publicaties

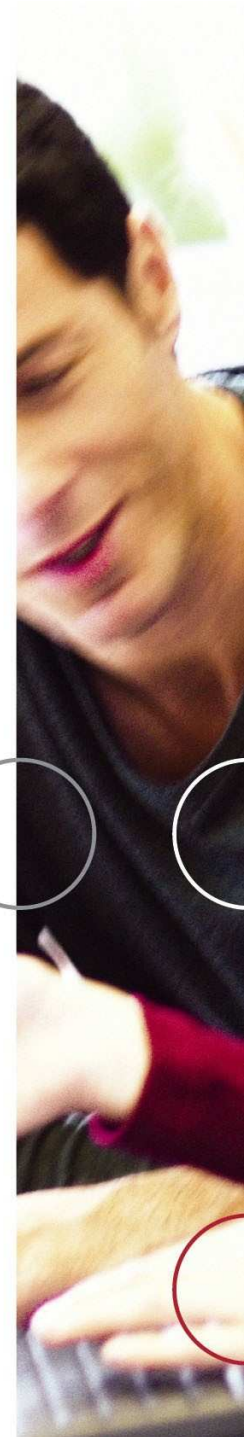
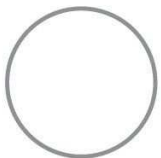
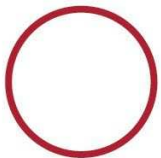



Principes uitrol binnen de Vlaamse Overheid

- E-Tendering
 - Stap 1
 - Pilootprojecten in 2009
 - Evaluatie pilootprojecten begin 2010
 - Centrale ondersteuning omtrent IT, juridische aspecten en communicatie
 - Kennisoverdracht naar plaatselijk team (juristen & IT)
 - Stap 2
 - In overleg met management wordt beslist om zowel elektronische als papieren offertes toe te laten
 - Stap 3
 - Alleen elektronische offertes worden toegelaten

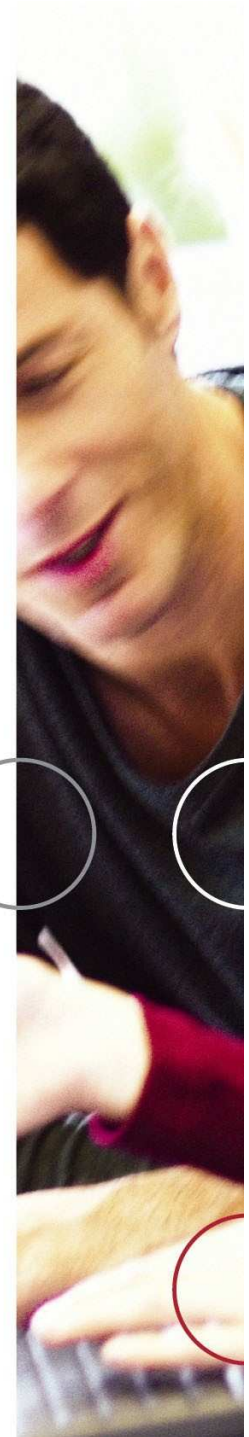
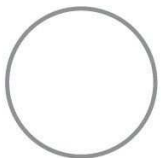
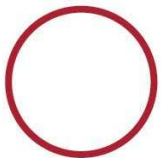



Service public fédéral
Personnel et Organisation

Samenwerking met andere overheden

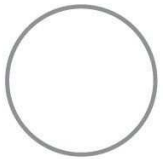

.be

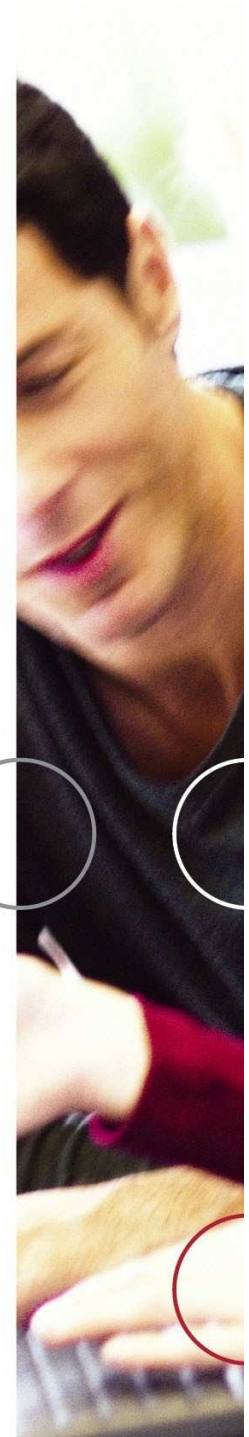



Samenwerking e-government

- 2006: samenwerkingsakkoord tussen federale overheid en de Gemeenschappen en Gewesten omtrent een geïntegreerd e-government:
 - o.a. samenwerking op gebied van de bouw, het gebruik van ontwikkelingen en diensten
 - Kan toegepast worden op het e-Procurement programma
 - Oplossingen worden maximaal opengesteld voor andere partijen
 - Samenwerkingsprotocollen kunnen op eenvoudige wijze worden afgesloten

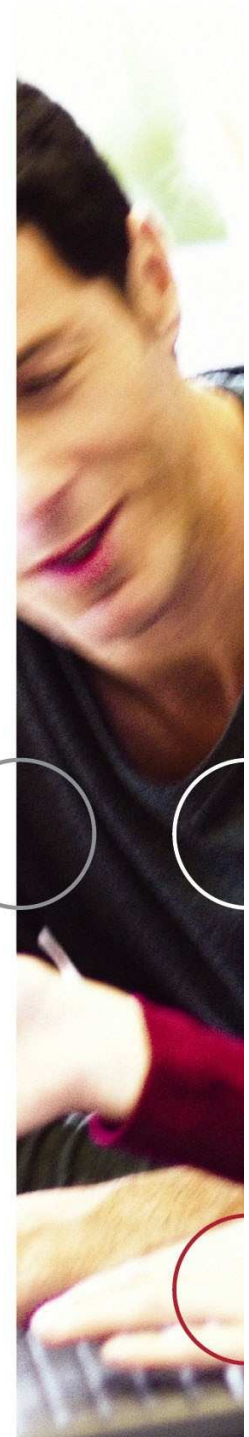
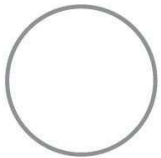



Voordelen samenwerking e-Procurement

- Overheid: investering hoeft maar 1x gerealiseerd worden (cofinanciering is mogelijk)
- Ondernemingen: het gebruik van dezelfde e-Procurement applicaties door meerdere/alle overheden betekent dat de ondernemingen hun werkzaamheden efficiënter kunnen organiseren

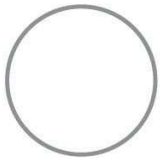
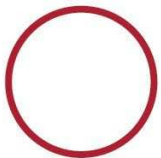



3 niveaus

- Niv 1: samenwerkingsakkoord betreffende het geïntegreerde e-government programma
- Niv 2: samenwerkingsprotocol
 - Ondertekend door bevoegde ministers
 - Algemene principes
 - Stabiel
- Niv 3: uitvoeringsakkoord
 - Ondertekend door verantwoordelijke ambtenaren
 - Praktische uitwerking
 - Kan eenvoudig wijzigen

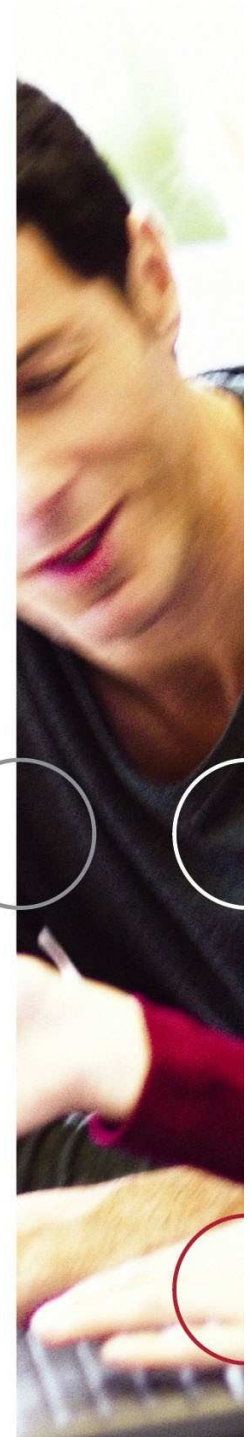
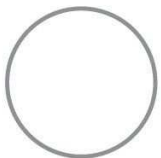



Samenwerkingsprotocol

- Analyse, de ontwikkeling, de ingebruikname, het gebruik en het beheer van de verschillende applicaties
- Wijze van samenwerking:
 - **Mede-eigenaarschap**: analyse en exploitatie gedragen door de verschillende eigenaars (cofinanciering)
 - **Partner**: participatie in definitie evolutief onderhoud (cofinanciering evolutief)
 - **Gebruiker**: geen inspraak
- Uitvoeringsakkoorden
 - Ondertekend door bevoegde ambtenaar
 - Aangeboden dienstverlening (SLA)
 - Financieringswijze en planning

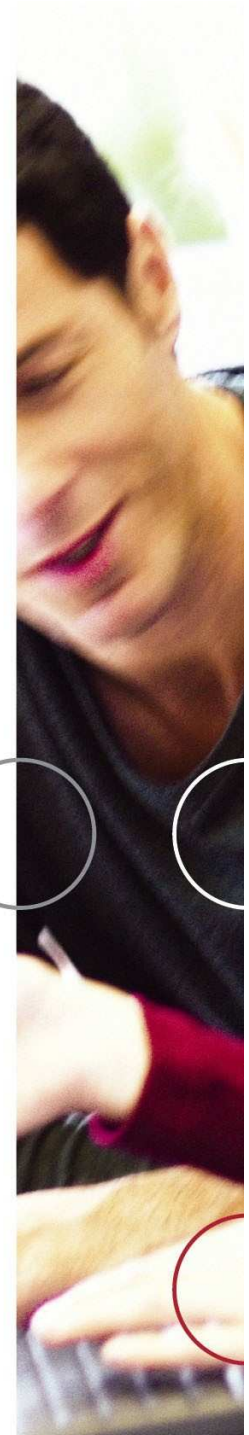
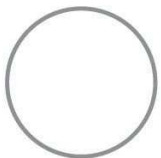



Service public fédéral
Personnel et Organisation

Mogelijke ondersteuning

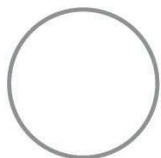
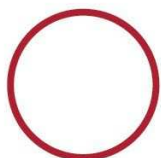

.be

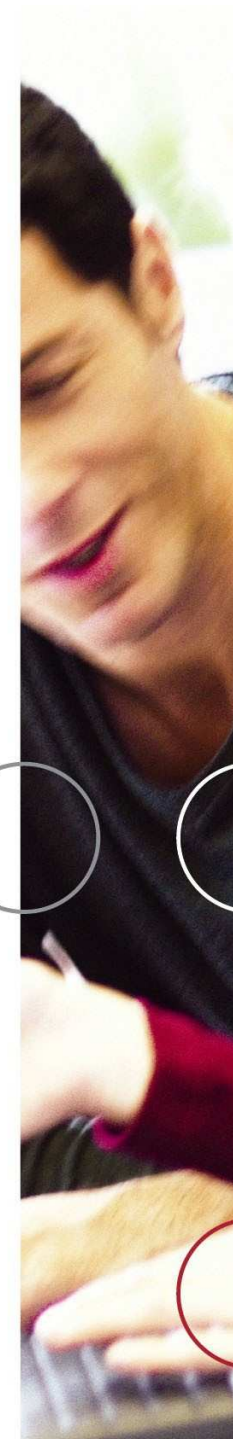



Voorstel (1)

- Aanpak:
 - Centraal gestuurde uitrol
 - Pilootprojecten
 - communicatiecampagne
- E-Notification
 - Opleiding door e-Procurement (2X ½ dag)
 - 2-talige helpdesk
 - Actieve Ondersteuning tijdens de pilootprojecten
 - Na evaluatie en bijsturing: algemene uitrol

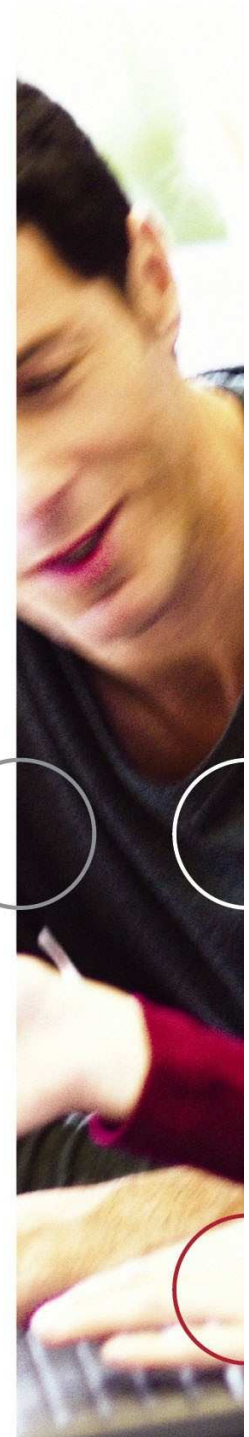
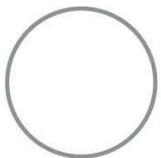



Voorstel (2)

E-Tendering

- Opleiding door e-Procurement (1/2 dag)
- 2-talige helpdesk
- Ondersteuning tijdens de pilootprojecten
 - Juridisch
 - IT
 - communicatie
- Elke verantwoordelijke beslist wanneer ook elektronische offertes zijn toegelaten (fase waarin en papier en elektronische offertes zijn toegelaten)
- Na evaluatie en bijsturing: alleen elektronische offertes zijn toegestaan

